

JSD100

Description:

- 1) Low forward voltage and leakage current
- 2) Low inductance package
- 3) High surge current capability



Typical Application:

- 1) Field supply for DC motors
- 2) Line rectifiers for transistorized AC motor controllers
- 3) Non-controllable rectifiers for AC/DC converter

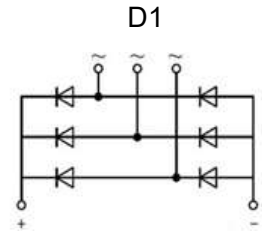

symbol

Absolute Maximum Ratings (Packaged into D1, unless otherwise specified, T_{CASE}=25°C)

Parameter	Test Conditions	Symbol	Values				Unit
			16	18	20	22	
Junction temperature range		T _J	-40~+150				°C
Storage temperature range		T _{STG}	-40~+125				°C
Repetitive peak reverse voltage		V _{RRM}	1600	1800	2000	2200	V
Non-repetitive peak reverse voltage		V _{RSM}	1700	1900	2100	2300	V
Output current	T _C =95°C	I _D	100				A
Forward surge current	1/2 cycle, Sine wave 50Hz, T _J =25°C	I _{FSM}	1000				A
Value for fusing		I ² t	5000				A ² s
RMS isolation voltage	A.C 50Hz(1s/1min)	V _{isol}	3600/3000				V



Three Phase Rectifier Bridge Module

Electrical Characteristics (Packaged into D1, unless otherwise specified, $T_{CASE}=25^{\circ}C$)

Parameter	Test Conditions	Symbol	Values			Unit
			Min.	Typ.	Max.	
Forward voltage	$I_F=100A, T_J=25^{\circ}C$	V_{FM}	-	-	1.35	V
Reverse leakage current	$V_R=V_{RRM}, T_J=25^{\circ}C$	I_{RRM}	-	-	0.5	mA
	$V_R=V_{RRM}, T_J=150^{\circ}C$		-	-	10	mA
Threshold voltage	$T_J=150^{\circ}C$, for power loss calculation only	V_{TO}	-	-	0.85	V
Slope resistance		r_T	-	-	4.0	m Ω

Thermal Characteristics (Packaged into D1, unless otherwise specified, $T_{CASE}=25^{\circ}C$)

Parameter	Test Conditions	Symbol	Values			Unit
			Min.	Typ.	Max.	
Thermal impedance (junction to case)	Per diode	$R_{th(j-c)}$	-	-	0.9	$^{\circ}C/W$
Mounting torque	Module and heatsink fixed torque, screw M5	M	4.25	-	5.75	Nm
	Electrode connection torque, screw M5		4.25	-	5.75	Nm
Weight			132			g
Case style			D1			

Ordering Information

<p>JS</p> <p>JieJie Semiconductor Co.,Ltd</p>	<p>D</p> <p>Diode module</p>	<p>100</p> <p>$I_D=100A$</p>	<p>/16</p> <p>16: $V_{RSM} \geq 1700V$ 18: $V_{RSM} \geq 1900V$ 20: $V_{RSM} \geq 2100V$ 22: $V_{RSM} \geq 2300V$</p>
--	-------------------------------------	--	---

Mechanical Characteristics(mm)

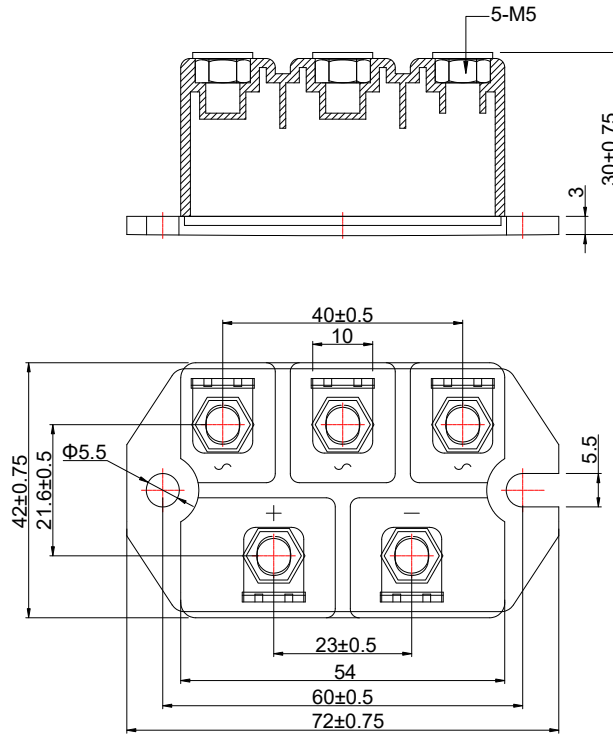

Performance Curves

FIG.1: Forward characteristics(per diode)

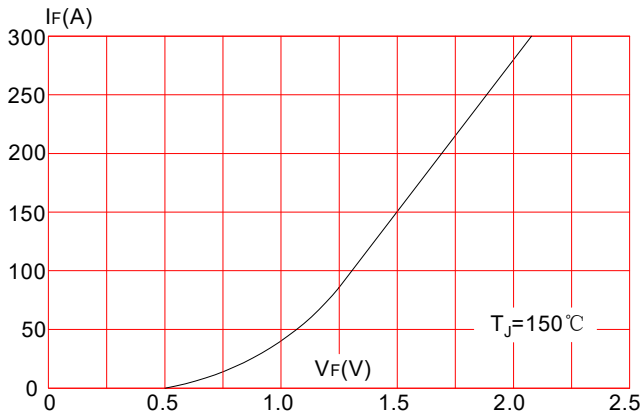

FIG.2: Peak on-state surge current

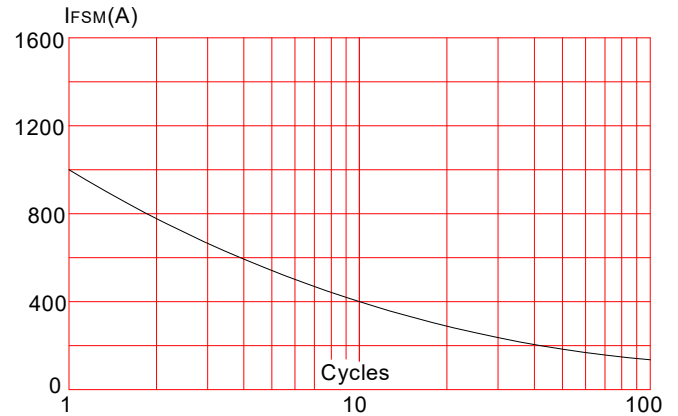

FIG.3: Forward current vs. case temperature

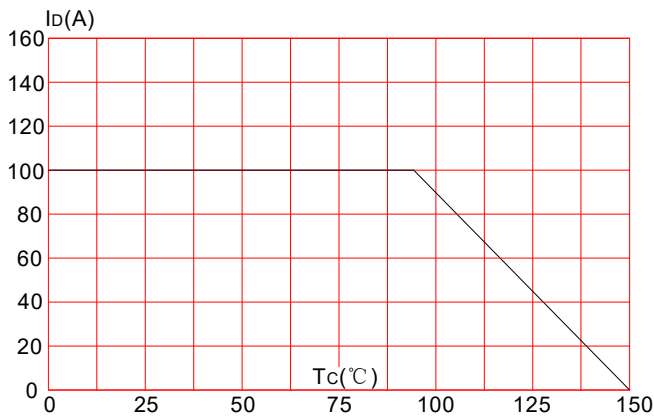
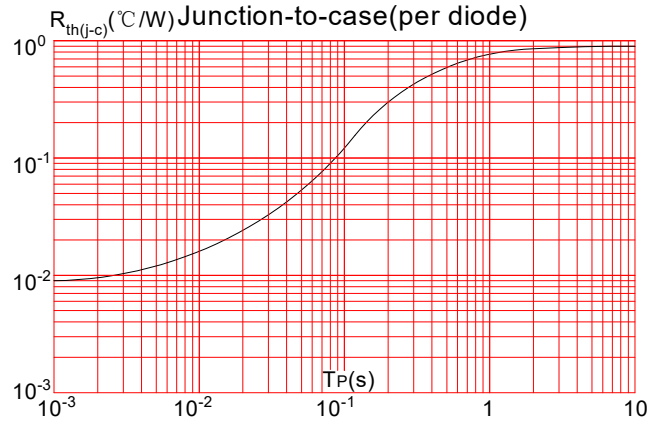

FIG.4: Maximum transient thermal impedance





Three Phase Rectifier Bridge Module

Information furnished in this document is believed to be accurate and reliable. However, JieJie Semiconductor Co.,Ltd assumes no responsibility for the consequences of use without consideration for such information nor use beyond it.

Information mentioned in this document is subject to change without notice, apart from that when an agreement is signed, JieJie complies with the agreement.

Products and information provided in this document have no infringement of patents. JieJie assumes no responsibility for any infringement of other rights of third parties which may result from the use of such products and information.

This document is the 1.3rd version which is made in 9-July-2022. This document supersedes and replaces all information previously supplied.

 is registered trademarks of JieJie Semiconductor Co.,Ltd. Copyright©2022 Semiconductor Co.,Ltd. Printed All rights reserved.