

TIP42 Series Transistor (PNP)

FEATURES

- Medium Power Linear Switching Applications
- Complement to TIP42/42A/42B/42C

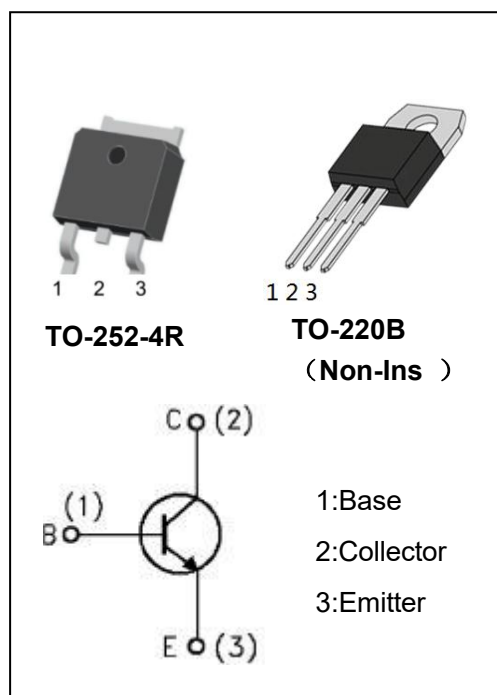

Absolute Maximum Ratings

Parameter	Symbol	TIP42	TIP42A	TIP42B	TIP42C	Unit
Collector-Base Voltage	V_{CBO}	-40	-60	-80	-100	V
Collector-Emitter Voltage	V_{CEO}	-40	-60	-80	-100	V
Emitter-Base Voltage	V_{EBO}	-5				V
Collector Current	I_C	-6				A
Collector Power Dissipation	P_C	20				W
Storage Temperature	T_{stg}	-55~150				°C/W
Operating junction temperature range	T_j	-55~150				°C



ELECTRICAL CHARACTERISTICS ($T_j=25^{\circ}\text{C}$ unless otherwise specified)

Parameter	Symbol	Test Conditions	Min	Typ	Max	Unit	
Collector- base breakdown voltage	V_{CBO}	TIP42	$I_c = -30\text{mA}$, $I_E = 0$	-40			V
		TIP42A		-60			
		TIP42B		-80			
		TIP42C		-100			
Collector-emitter sustaining voltage	$V_{CEO(SUS)}$	TIP42	$I_c = -30\text{mA}$, $I_B = 0$	-40			V
		TIP42A		-60			
		TIP42B		-80			
		TIP42C		-100			
Emitter - base breakdown voltage	V_{EBO}	$I_E = -100\ \mu\text{A}$, $I_C = 0$	-5				
Collector-base cut-off current	I_{CBO}	TIP42	$V_{CB} = -40\text{V}$, $I_E = 0$			-0.1	μA
		TIP42A	$V_{CB} = -60\text{V}$, $I_E = 0$				
		TIP42B	$V_{CB} = -80\text{V}$, $I_E = 0$				
		TIP42C	$V_{CB} = -100\text{V}$, $I_E = 0$				
Collector- emittercut-off current	I_{CEO}	TIP42/42A	$V_{CE} = -30\text{V}$, $I_E = 0$			-0.7	mA
		TIP42B/42C	$V_{CE} = -60\text{V}$, $I_E = 0$				
Collector- emittercut-off current	I_{CES}	TIP42	$V_{CE} = -40\text{V}$, $I_E = 0$			-400	μA
		TIP42A	$V_{CE} = -60\text{V}$, $I_E = 0$				
		TIP42B	$V_{CE} = -80\text{V}$, $I_E = 0$				
		TIP42C	$V_{CE} = -100\text{V}$, $I_E = 0$				
Emitter cut-off current	I_{EBO}	$V_{EB} = -5\text{V}$, $I_C = 0$			-1	mA	
Collector-emitter saturation voltage	$V_{CE(sat)}$	$I_C = -6\text{A}$, $I_B = -600\text{mA}$			-1.5	V	
Base - emitter saturation voltage	$V_{BE(sat)}$	$V_{CE} = -4\text{V}$, $I_C = -6\text{A}$			-2		
DC current gain	$h_{FE(1)}$	$V_{CE} = -4\text{V}$, $I_C = -300\text{mA}$	30				
	$h_{FE(2)}$	$V_{CE} = -4\text{V}$, $I_C = -3\text{A}$	15		75		
Transition frequency	f_T	$V_{CE} = -10\text{V}$, $I_C = -500\text{mA}$	3			MHz	



ELECTRICAL CHARACTERISTICS

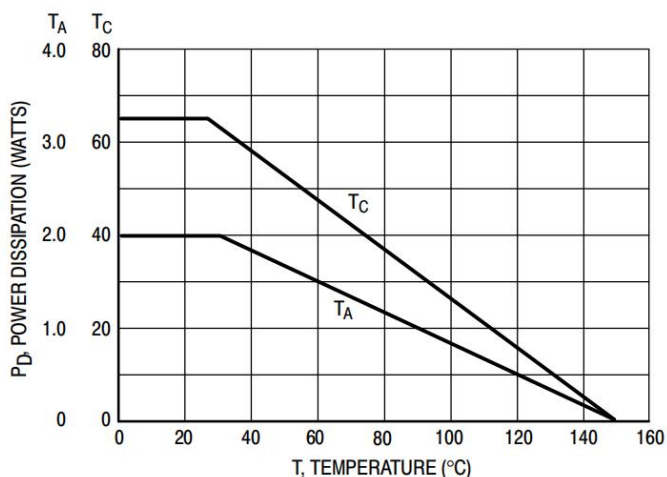

Figure 1. Power Derating

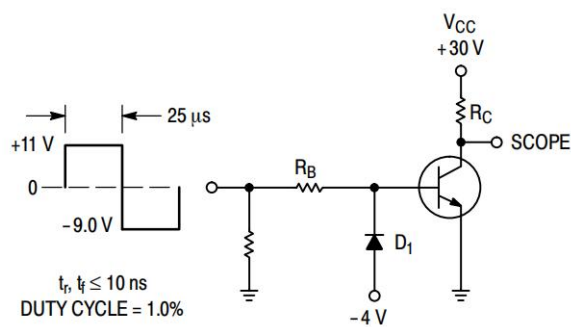

Figure 2. Switching Time Test Circuit

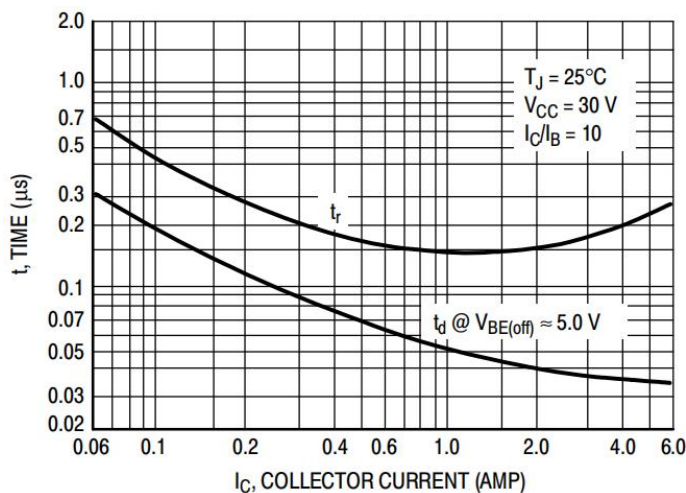

Figure 3. Turn-On Time

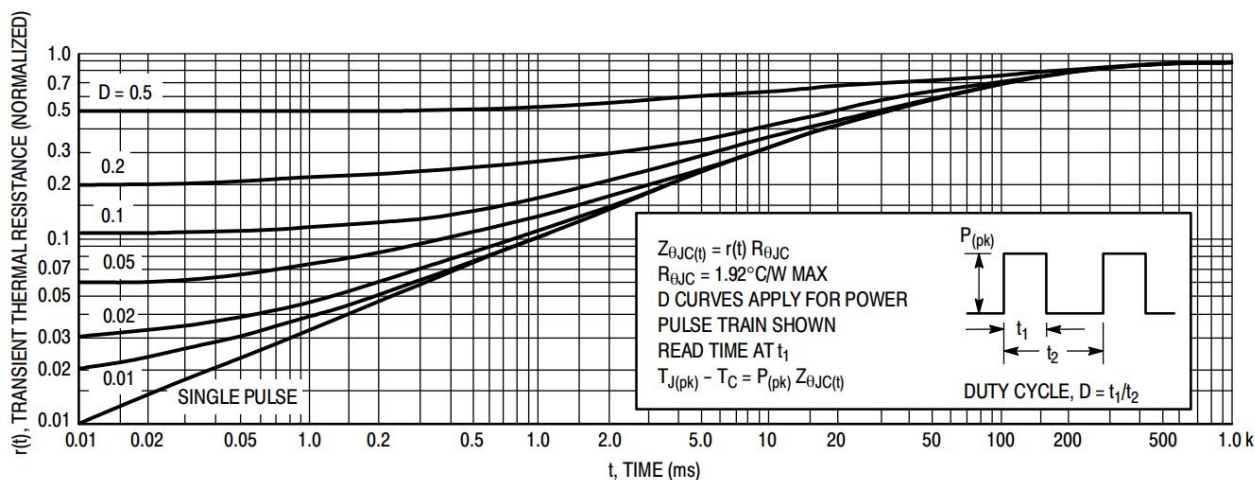
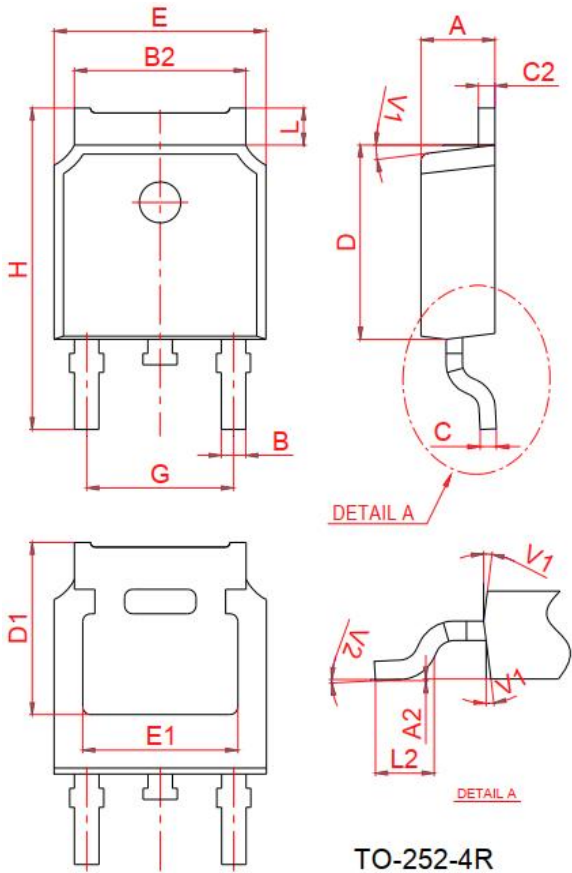

Figure 4. Thermal Response



PACKAGE MECHANICAL DATA



Ref.	Dimensions					
	Millimeters			Inches		
	Min.	Typ.	Max.	Min.	Typ.	Max.
A	2.2		2.4	0.087		0.094
A2	0		0.1	0		0.004
B	0.66		0.86	0.026		0.034
B2	5.1		5.46	0.201		0.215
C	0.46		0.58	0.018		0.023
C2	0.44		0.58	0.017		0.023
D	5.9		6.3	0.232		0.248
D1	5.30REF			0.211REF		
E	6.4		6.8	0.252		0.268
E1	4.63			0.182		
G	4.372		4.772	0.172		0.188
H	9.8		10.4	0.386		0.409
L	1.09		1.21	0.043		0.048
L2	1.35		1.65	0.053		0.065
V1		7°			7°	
V2	0°		6°	0°		6°

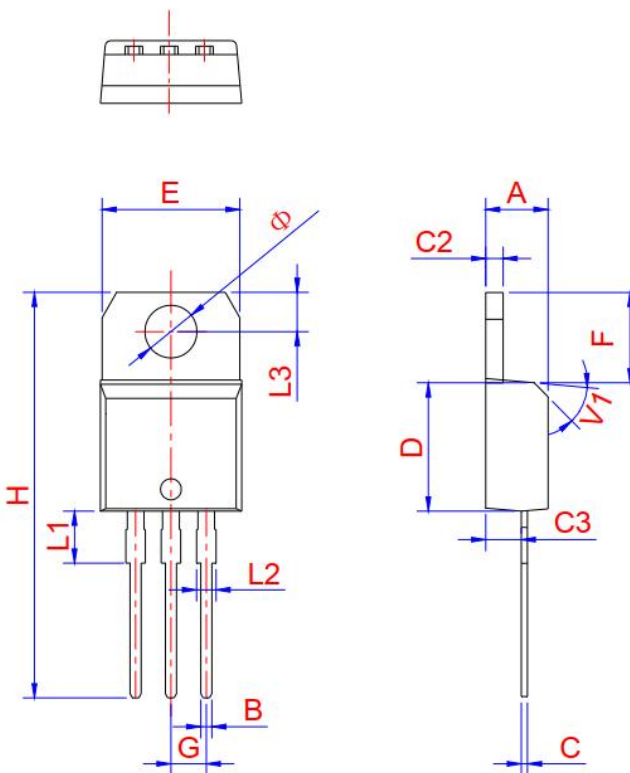

Ref.	Dimensions					
	Millimeters			Inches		
	Min.	Typ.	Max.	Min.	Typ.	Max.
A	4.4	4.47	4.6	0.173	0.176	0.181
B	0.61		0.88	0.024		0.035
C	0.46	0.50	0.7	0.018	0.02	0.028
C2	1.21	1.27	1.32	0.048	0.050	0.052
C3	2.4		2.72	0.094		0.107
D	8.6		9.7	0.339		0.382
E	9.8		10.4	0.386		0.409
F	6.55		6.95	0.258		0.274
G		2.54			0.1	
H	28		29.8	1.102		1.173
L1		3.75			0.148	
L2	1.14		1.7	0.045		0.067
L3	2.65		2.95	0.104		0.116
V1		45°			45°	
Φ	3.7	3.75	3.8	0.145	0.147	0.149

MAKING

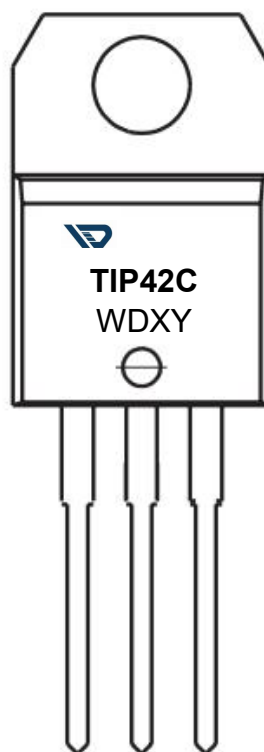
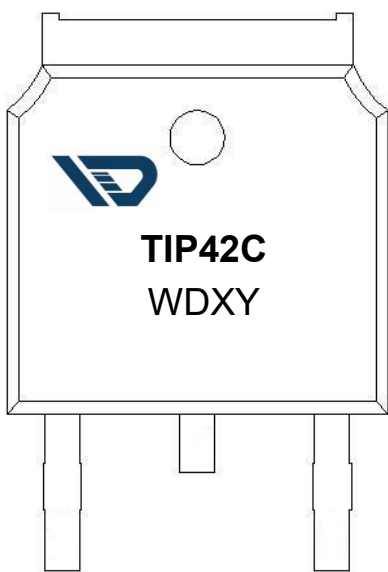

TIP42C = Device code

WD = Company Code

X = Year code

Y= Week code

Information furnished in this document is believed to be accurate and reliable. However, Jiangsu Weida Semiconductor Co., Ltd assumes no responsibility for the consequences of use without consideration for such information nor use beyond it.

Information mentioned in this document is subject to change without notice, apart from that when an agreement is signed, Jiangsu Weida Semiconductor Co., Ltd complies with the agreement.

Products and information provided in this document have no infringement of patents. Jiangsu Weida Semiconductor Co., Ltd assumes no responsibility for any infringement of other rights of third parties which may result from the use of such products and information.