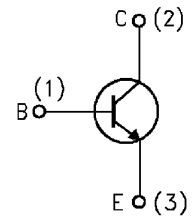
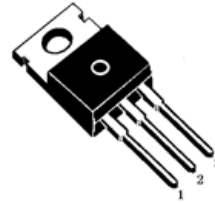

**FEATURES**

- High Voltage
- Fast Switching Speed:  $t_f = 750$  ns (max)
- Low Saturation Voltage:  $V_{CE(sat)} = 1$  V (max) @ 5 A
- Pb-Free Packages are Available\*

**MAXIMUM RATINGS ( $T_a=25^\circ\text{C}$  unless otherwise noted)**

Symbol	Parameter	Value	Unit
$V_{CBO}$	Collector-Base Voltage	400	V
$V_{CEO}$	Collector-Emitter Voltage	200	V
$V_{EBO}$	Emitter-Base Voltage	6	V
$I_C$	Collector Current	7	A
$P_C$	Collector Power Dissipation	60	W
$R_{\theta JA}$	Thermal Resistance from Junction to Ambient	62.5	$^\circ\text{C}/\text{W}$
$T_j$	Junction Temperature	150	$^\circ\text{C}$
$T_{stg}$	Storage Temperature	-55~+150	$^\circ\text{C}$

**ELECTRICAL CHARACTERISTICS ( $T_a=25^\circ\text{C}$  unless otherwise specified)**

Parameter	Symbol	Test conditions	Min	Typ	Max	Unit
Collector-base breakdown voltage	$V_{(BR)CBO}$	$I_C=100\mu\text{A}, I_E=0$	400			V
Collector-emitter breakdown voltage	$V_{(BR)CEO}^*$	$I_C=100\text{mA}, I_B=0$	200			V
Emitter-base breakdown voltage	$V_{(BR)EBO}$	$I_E=100\mu\text{A}, I_C=0$	6			V
Collector cut-off current	$I_{CES}$	$V_{CB}=400\text{V}, I_E=0$			5	mA
Collector cut-off current	$I_{CES}$	$V_{CB}=250\text{V}, I_E=0$			1	mA
Collector cut-off current	$I_{CBO}$	$V_{CB}=300\text{V}, I_E=0$			5	$\mu\text{A}$
Emitter cut-off current	$I_{EBO}$	$V_{EB}=6\text{V}, I_C=0$			1	mA
DC current gain	$h_{FE}$	$V_{CE}=5\text{V}, I_C=1\text{A}$	50		100	
Collector-emitter saturation voltage	$V_{CE(sat)}^*$	$I_C=5\text{A}, I_B=500\text{mA}$			1	V
Base-emitter saturation voltage	$V_{BE(sat)}^*$	$I_C=5\text{A}, I_B=500\text{mA}$			1.2	V
Collector output capacitance	$C_{ob}$	$V_{CB}=10\text{V}, I_E=0, f=1\text{MHz}$		80		pF
Transition frequency	$f_T$	$V_{CE}=5\text{V}, I_C=0.2\text{A}, f=10\text{MHz}$	10			MHz

\*Pulse test: pulse width  $\leq 300\mu\text{s}$ , duty cycles  $\leq 2.0\%$ .

## Typical Characteristics

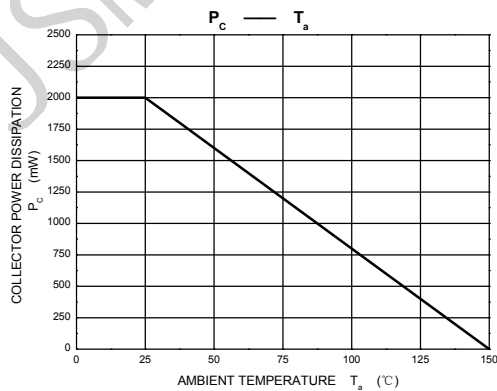
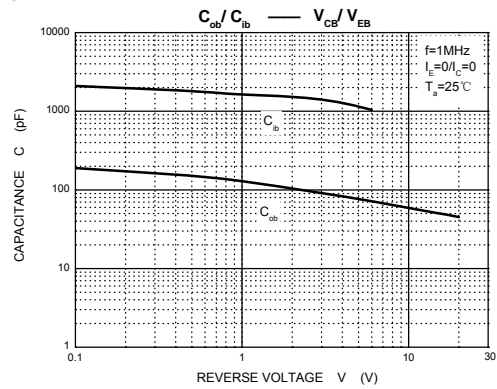
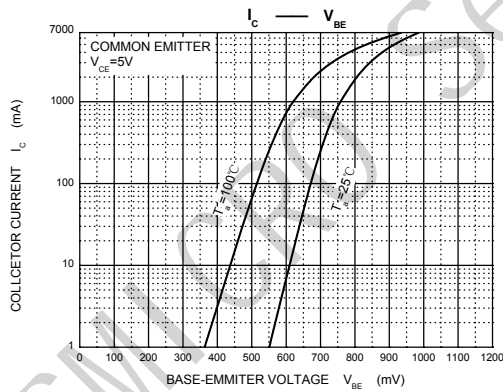
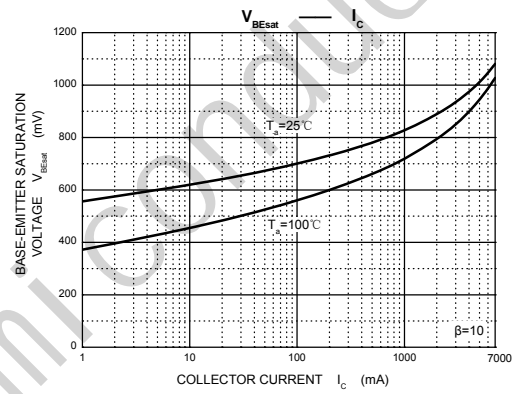
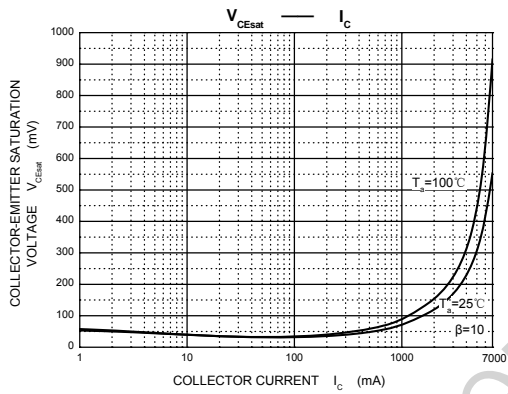
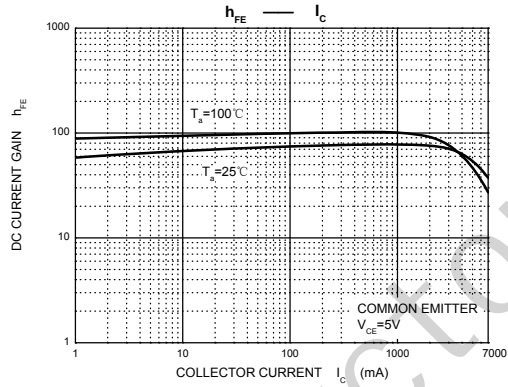
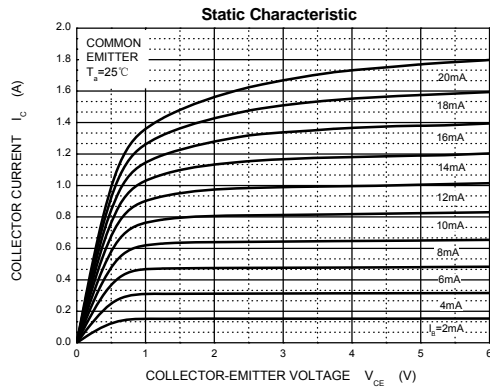

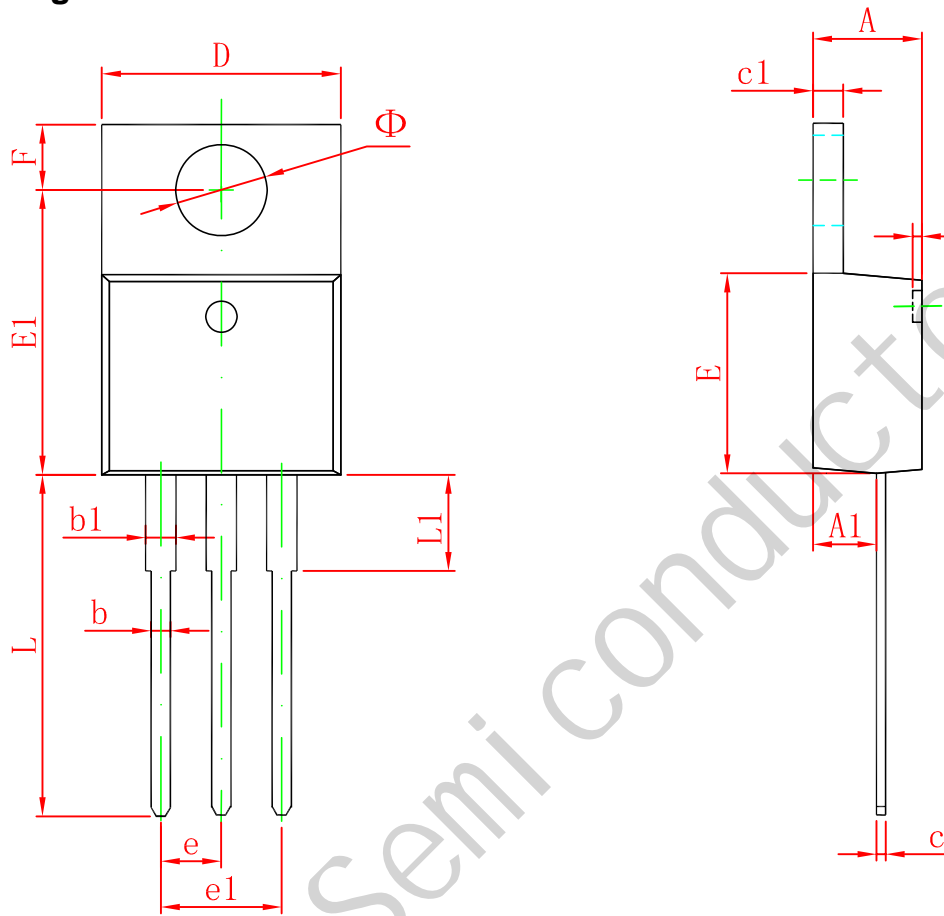
**TO-220-3L Package Outline Dimensions**

Symbol	Dimensions In Millimeters		Dimensions In Inches	
	Min	Max	Min	Max
A	4.470	4.670	0.176	0.184
A1	2.520	2.820	0.099	0.111
b	0.710	0.910	0.028	0.036
b1	1.170	1.370	0.046	0.054
c	0.310	0.530	0.012	0.021
c1	1.170	1.370	0.046	0.054
D	10.010	10.310	0.394	0.406
E	8.500	8.900	0.335	0.350
E1	12.060	12.460	0.475	0.491
e	2.540 TYP		0.100 TYP	
e1	4.980	5.180	0.196	0.204
F	2.590	2.890	0.102	0.114
h	0.000	0.300	0.000	0.012
L	13.400	13.800	0.528	0.543
L1	3.560	3.960	0.140	0.156
Φ	3.735	3.935	0.147	0.155